

**AC - ACF - ACHM SERIES**



**ACF SERIES**

**ACHM SERIES**

**AC SERIES**

***Air Cooled***

**LIQUID COOLERS**

- Thermal capacity to 100 hp (75 Kw).
- Computerized selection program.
- Standard ports NPT, optional SAE straight thread or flange connections.
- Optional: built-in bypass relief valve.
- Operating temperature of 300° F and pressure of 300PSI.
- Computer generated data sheet available for any application
- Custom designs to fit your needs.
- Cools: Fluid Power Systems, Lubrication Systems, Hydraulic Presses, Gear Drives, Torque Convertors, Machine Tools, Etc...

# AC, ACF & ACHM Series overview

---



## **AC SERIES with electric drive**

Industrial air-cooled liquid coolers, three row rolled tube servicable core heat exchangers with direct electric drive cooling fan, OSHA guard, and air directing louvers. Rated operating temperature of 300°F at 300 PSIG. Services standard flow rates from 2 to 120 GPM. Thermal capacity up to 100 hp (75Kw). NPT, flange, or SAE straight thread port connections. Optional built-in bypass relief valve 30 PSI or 65 PSI. Can be modified to meet your requirements. Suitable for most hydraulic oils, lubrications oils, synthetic compressor oils, phosphate ester, ethylene glycol, and many other fluids compatible with listed material.

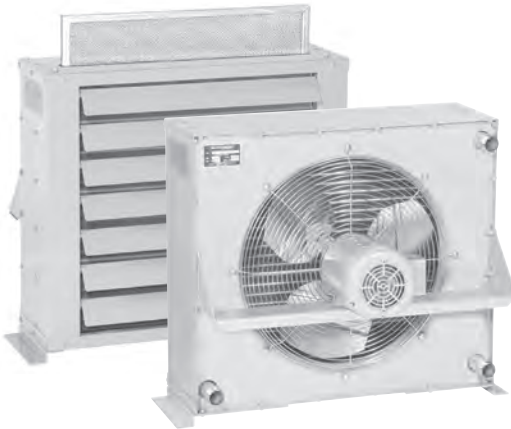

## **ACF SERIES with electric drive**

Industrial air-cooled liquid coolers, three row rolled tube heat exchangers with washable internal filter located between the fan and core, direct electric drive cooling fan, OSHA guard, and air directing louvers. Washable filter helps prevent airborne dust and debris from collecting on the core fins for continued optimum performance. Filter can be easily removed within minutes from the filter track, cleaned or replaced for continued service. Rated operating temperature of 300°F at 300 PSIG. Thermal capacity up to 100 hp (75Kw). Optional built-in bypass relief valve 30 PSI or 65 PSI. Can be modified to meet your requirements. The ACF series can be used in environments such as Sawmills or foundries, etc...where excessive airborne dust or debris may be present.



## **ACHM SERIES with hydraulic drive**

Industrial air-cooled liquid coolers, three row rolled tube heat exchangers with hydraulic drive cooling fan, OSHA guard, and air directing louvers. Rated operating temperature of 300°F at 300 PSIG. Services standard flow rates from 2 to 120 GPM. Thermal capacity up to 100 hp (75Kw). NPT, flange, or SAE straight thread port connections. Optional built-in bypass relief valve 30 PSI or 65 PSI. Can be modified to meet your requirements. Suitable for most hydraulic oils, lubrications oils, synthetic compressor oils, phosphate ester, ethylene glycol, and many other fluids compatible with listed material.



## **AOCH SERIES**

Industrial air-cooled liquid coolers, dimensionally similar to AC & ACHM Series with higher capacity and performance. Six row rolled tube heat exchangers with direct electric drive cooling fan, OSHA guard, air directing louvers and Servicable Core®. Rated operating temperature of 300°F at 300 PSIG. Can be modified to meet your requirements. Suitable for most hydraulic oils, lubrications oils, synthetic compressor oils, phosphate ester, ethylene glycol, and many other fluids compatible with listed material.

# AC, ACF & ACHM Series *construction*

## HIGH PERFORMANCE TURBULATOR



Exclusive American Industrial Turbulators (installed in every flow tube) increase heat transfer by more than 100%.

American Industrial Turbulators eliminate the laminar flow condition normally associated with other smooth tube heat exchangers. High viscosity hydraulic and lubricating oils are easily cooled by this new state-of-the-art turbulator.

## SUPERIOR COOLING FINNS

Seamless copper tubes are mechanically bonded to highly efficient aluminum cooling fins. Die-formed fin collars provide a durable precision fit for maximum heat transfer.

Custom fin design forces air to become turbulent and carry heat away more efficiently than old flat fin designs.



## CONSTRUCTION MATERIALS & RATINGS

Standard Construction Materials		Optional Construction Materials	Standard Unit Ratings	
Tubes	Copper	Carbon Steel	Operating Pressure	300 psig
Fins	Aluminum	Copper	Operating Temperature	300 °F
Turbulators	Steel	Brass	Max. Flow Internal Relief	38 gpm
Manifold	Steel	Stainless Steel	Max. Fan Over-speed	10 %
Connection pipes	Steel	Stainless Steel	Max. Ambient Conditions	104 °F
Cabinet & frame	Steel	Galvanized Steel, 316L Stainless Steel	Altitude	0-3300 ft.
Fan Blade	Aluminum with steel hub	Plastic, Non-sparking		
Fan Guard	Zinc plated steel			

## Accessories

Electrical Temperature controller with Bulb Well Assembly (for Air / Liquid Coolers)

Part Number	Description
310-4011	TC-511 with 6-Foot Capillary Tube & Bulb Well
310-4002	TC-511 with 20-Foot Capillary Tube & Bulb Well
310-2025	Replacement Bulb Well TC-511



# AC, ACF & ACHM Series performance

## ONE PASS

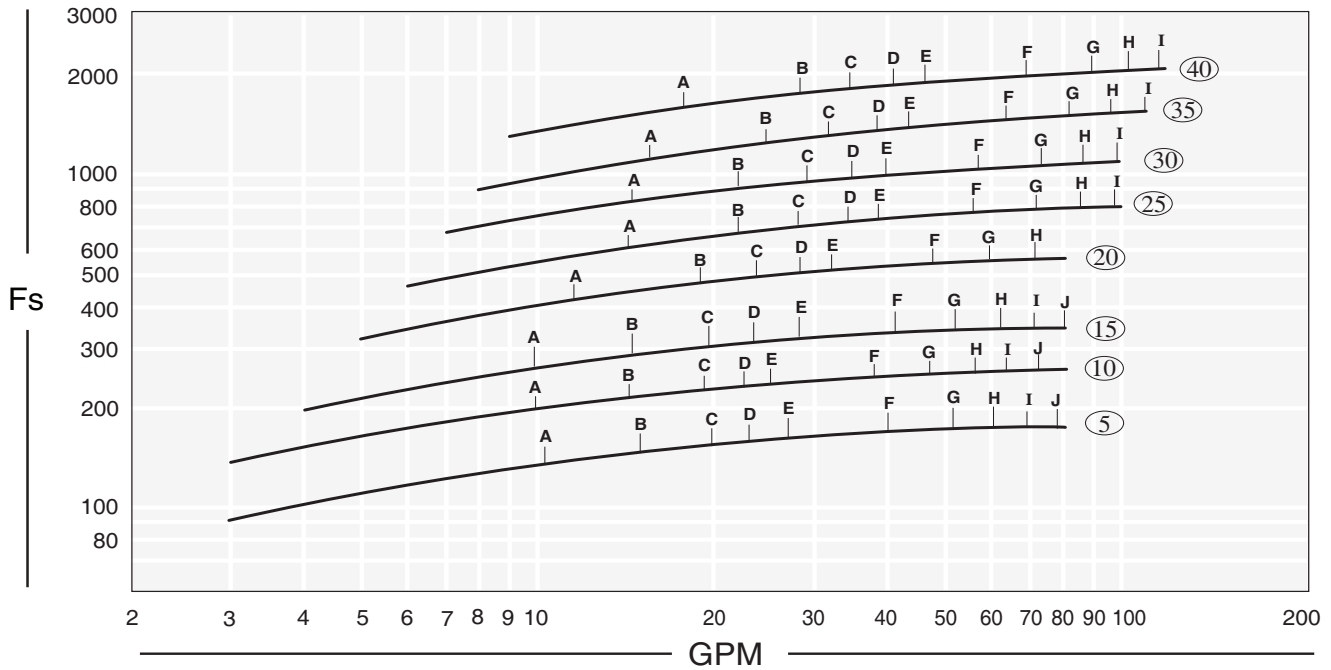

## TWO PASS

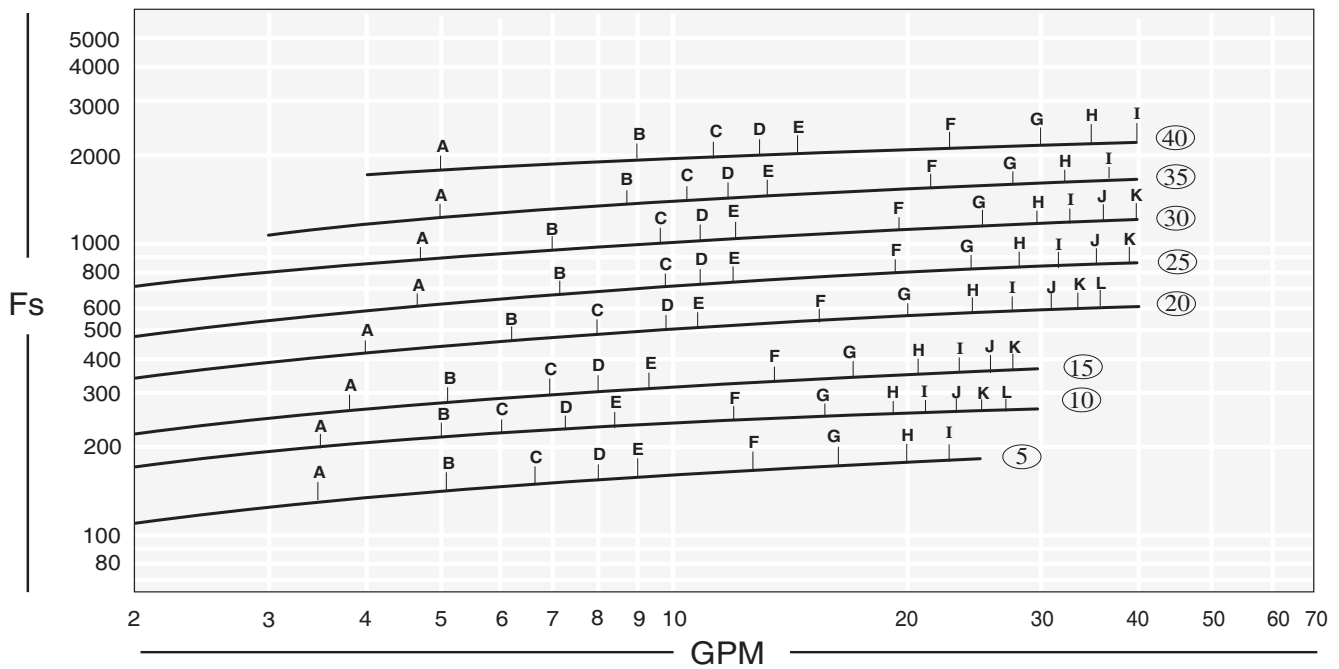

PERFORMANCE CALCULATION	OIL PRESSURE DROP (PSI) CODE
$F_s = \frac{\text{Horsepower to be removed (HP)} \times 2545 \times C_v}{\text{°F (Oil Leaving* - Ambient Air Entering)}} = \frac{\text{BTU}}{\text{hr °F}}$	A = 1 PSI    D = 4 PSI    G = 15 PSI    J = 30 PSI B = 2 PSI    E = 5 PSI    H = 20 PSI    K = 35 PSI C = 3 PSI    F = 10 PSI    I = 25 PSI    L = 40 PSI

\*Represents desired fluid leaving the cooler.

*Note:* When a model selection has been made, record whether the selection was from the one pass curve or the Two Pass curve so that the unit can be properly plumbed. Incorrect installation can seriously affect the performance.

# AC, ACF & ACHM Series selection

## Sizing

The performance curves provided are for petroleum oil at 50 ssu viscosity. However, fluids with characteristics other than the above mentioned may be used by applying a correction factor.

## Heat Load

If the heat load is unknown, a horsepower value can be calculated by first determining the systems total potential. For a basic hydraulic system, it is helpful to know whether the system is open loop (with a large reservoir) or closed loop (normally on mobile equipment, with a very small reservoir). System potentials may be calculated quickly by using one of the two methods below.

There are some system parameters that will be required to properly accomplish the sizing calculations. Without system parameters, it is difficult to determine the optimal heat exchanger size. Normally many of the system parameters can be found on hydraulic schematics or on tags located on the actual equipment. Following are some basic parameters that you should try to acquire before attempting the sizing calculations. However, it is not necessary to have every parameter listed below.

- Main system flow rate (gpm) & operating pressure (psi).
- Electric motor HP driving hydraulic pump (if more than one add up the Hp for all).
- Desired temperature (°F).
- Fluid type (SAE 10, 20, 30, etc....).
- Ambient air temperature (warmest day).
- Desired fan drive (hydraulic, electric, 12-24V DC, etc...).
- BTU's or HP to be cooled (normally given for lubrication systems).
- Maximum pressure drop allowed through the heat exchanger.
- Space available for heat exchanger (LxWxH).
- External air condition (dirty, papers, etc...).

## Method 1

Normally used for open loop circuits. Multiply the main hydraulic systems Electric Motor Name plate Horsepower by a heat removal factor (normally 30-50%).

Example: 50 HP motor x 0.3 = 15 HP heat load

## Method 2

Normally used when the HP input potential is unknown or for mobile applications where diesel engines operate the entire system.

Multiply system pressure by the flow rate of the main system divided by 1714 equals system potential (HP). Multiply the system HP by a heat removal factor (Normally 25-35%). Note: In some closed loop systems only a portion of the total system flow is directed through the heat exchanger. This may affect the cooler selection process substantially. You may contact our factory for additional technical assistance.

Example:  $\frac{(2000 \text{ psi} \times 30 \text{ gpm})}{1714} = [35 \text{ HP} \times .25] = 8.75 \text{ HP heat load}$

## Determining Fs value

To determine the proper size heat exchanger for your application, use the following equation to first determine the (Fs) factor:

$$F_s = \frac{\text{heat load (HP)} \times 2545 \times C_v}{\text{°F (oil leaving - air entering)}}$$

Example:

Heat load = 8.75 HP

$C_v = 1.14$  (SAE 20) determined from chart. [Located on page 5.]

Desired operating temperature = 120 °F

Ambient air temp. = 100 °F

$$F_s = \frac{8.75 \times 2545 \times 1.14}{120 \text{ °F} - 100 \text{ °F}} = 1269$$

## Selection

To select a model, locate the flow rate (GPM) at the bottom of the flow vs Fs graph (on page 4). Proceed upward until the GPM flow rate intersects with the calculated Fs. The curve closest above the intersection point will meet these conditions.

Example: **Fs = 1269 = Model = AC,ACHM,ACF - 35**  
**GPM = 40**  
**PASSES = 1**

## Pressure differentials

Determine the oil pressure drop from the curves as indicated. For viscosities other than 50 ssu, multiply the actual indicated pressure drop for your GPM flow by the value shown in the pressure differential curve for your viscosity value.

Example: Model 35 @ 40 gpm & 50 ssu -1 pass curve-

Indicated pressure drop 4.2 psi (Approx)

{ 4.2 psi x 2.8Cp (for SAE-20 oil) } = 11.76 corrected psi

Average Liquid Temperature	Cv VISCOSITY CORRECTION FACTORS																
	SAE 5	SAE 10	SAE 20	SAE 30	SAE 40	ISO 22	ISO 32	ISO 46	ISO 68	ISO 100	ISO 150	ISO 220	ISO 320	MIL-L-7808	POLYGLYCOL	PHOSPHATE ESTER	50% ETHYLENE GLYCOL & WATER
100	1.11	1.15	1.25	1.38	1.45	1.08	1.14	1.18	1.26	1.37	1.43	1.56	1.84	1.19	0.92	0.83	0.85
110	1.09	1.12	1.20	1.32	1.40	1.06	1.13	1.16	1.25	1.31	1.39	1.48	1.67	1.14	0.89	0.80	0.84
120	1.06	1.10	1.17	1.27	1.35	1.04	1.11	1.14	1.20	1.27	1.35	1.40	1.53	1.09	0.88	0.79	0.84
130	1.04	1.08	1.13	1.24	1.29	1.03	1.09	1.13	1.17	1.24	1.30	1.34	1.44	1.05	0.85	0.77	0.83
140	1.03	1.05	1.11	1.19	1.25	1.02	1.08	1.10	1.16	1.20	1.26	1.30	1.39	1.03	0.84	0.76	0.82
150	1.01	1.04	1.09	1.16	1.22	1.02	1.06	1.09	1.13	1.17	1.22	1.27	1.33	1.01	0.83	0.74	0.82
200	0.98	0.99	1.01	1.04	1.07	0.98	0.99	1.00	1.01	1.02	1.08	1.09	1.14	0.98	0.79	0.71	0.80
250	0.95	0.96	0.97	0.98	0.99	0.95	0.96	0.96	0.96	0.97	0.99	1.01	1.02	0.97	0.76	0.69	0.79

Average Liquid Temperature	Cp PRESSURE DROP CORRECTION FACTORS																
	SAE 5	SAE 10	SAE 20	SAE 30	SAE 40	ISO 22	ISO 32	ISO 46	ISO 68	ISO 100	ISO 150	ISO 220	ISO 320	MIL-L-7808	POLYGLYCOL	PHOSPHATE ESTER	50% ETHYLENE GLYCOL & WATER
100	2.00	2.40	4.40	6.40	8.80	1.07	1.53	1.82	2.54	4.19	6.44	9.38	13.56	1.26	3.00	3.50	0.730
110	1.70	2.10	3.60	5.10	6.70	1.04	1.45	1.72	2.35	3.73	5.70	8.33	11.63	1.20	2.40	2.90	0.720
120	1.50	1.80	3.00	4.20	5.60	1.02	1.38	1.60	2.15	3.26	4.91	7.23	9.73	1.14	2.10	2.50	0.709
130	1.40	1.60	2.60	3.40	4.50	0.99	1.30	1.49	1.94	2.80	4.14	6.19	7.80	1.08	1.90	2.20	0.698
140	1.30	1.50	2.23	2.90	3.70	0.97	1.23	1.38	1.75	2.38	3.47	5.20	6.11	1.03	1.90	2.00	0.686
150	1.20	1.30	1.90	2.50	3.10	0.95	1.17	1.30	1.61	2.04	2.90	4.35	4.77	0.98	1.70	1.90	0.676
200	0.93	0.96	1.20	1.40	1.60	0.89	0.99	1.08	1.18	1.33	1.59	1.74	1.95	0.90	1.20	1.30	0.635
250	0.81	0.82	0.92	0.97	1.05	0.85	0.93	0.96	1.03	1.11	1.21	1.22	1.23	0.83	1.00	1.05	0.556

# AC Series *dimensions*

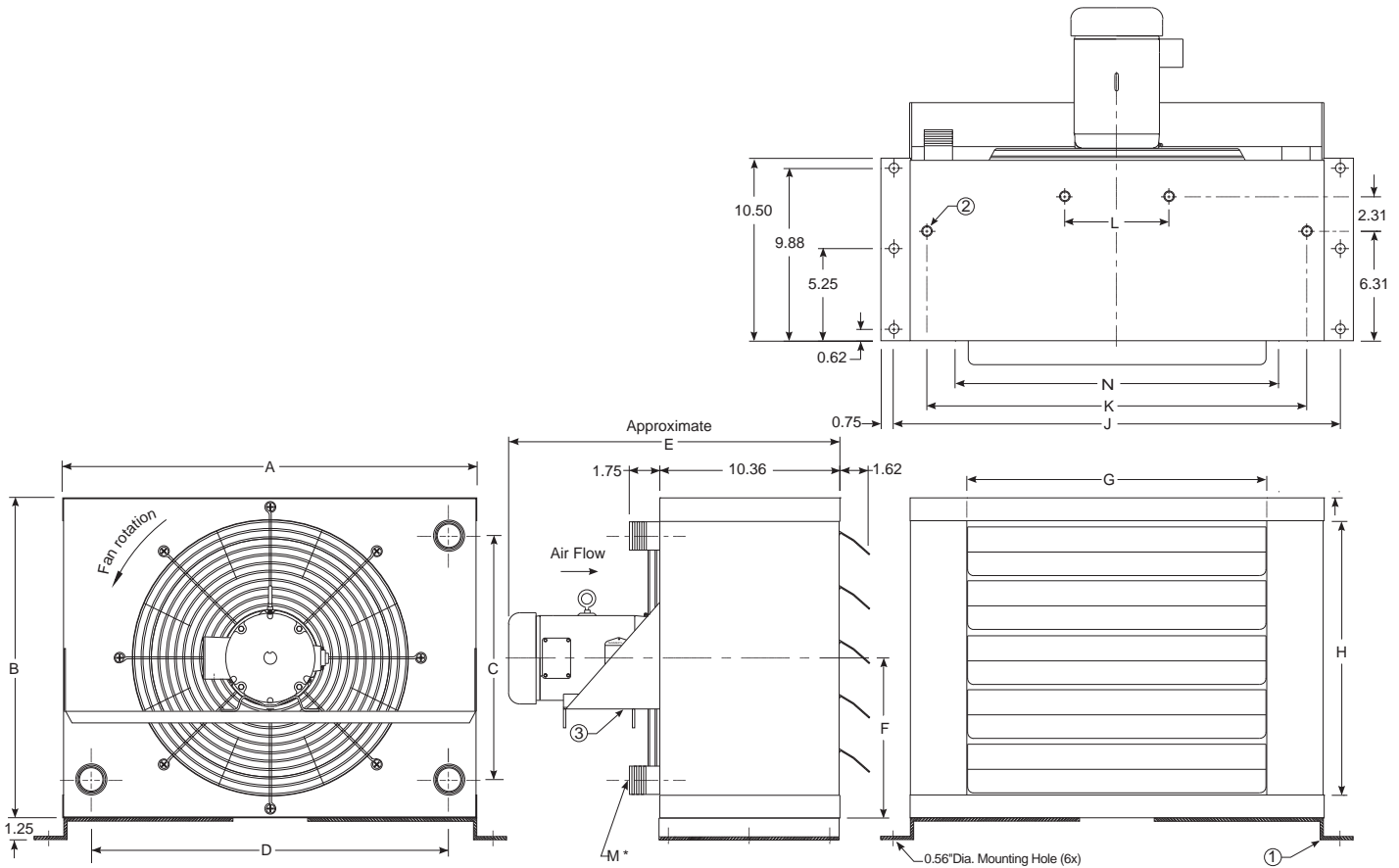

DIMENSIONS (inches)													
Model	A	B	C	D	E	F	G	H	J	K	L	M NPT	M SAE
AC - 5 - *	14.81	11.81	7.69	11.69	17.56	5.90	8.31	9.19	16.81	12.94	—	1.00	16 SAE
AC - 10 - *	19.00	13.13	8.88	15.88	17.13	6.56	12.50	10.50	21.00	17.13	—	1.00	1 5/16 - 12UN-2B
AC - 15 - *	20.38	15.75	11.50	17.25	17.44	7.88	13.88	13.12	22.38	18.50	—	1.00	Thread
AC - 20 - *	23.81	18.38	14.00	20.56	17.56	9.19	17.19	15.75	25.81	21.81	—	1.25	
AC - 25 - *	26.68	23.63	19.25	23.56	17.56	11.81	20.19	21.00	28.68	24.81	—	1.25	20 SAE
AC - 30 - *	31.63	27.56	23.19	28.50	17.63	13.78	25.13	24.94	33.63	29.75	11.00	1.25	1 5/8 - 12UN-2B
AC - 35 - *	33.81	30.19	25.81	30.69	20.75	15.09	27.31	27.56	35.81	31.94	11.00	1.25	Thread
AC - 40 - *	41.63	36.75	32.38	38.50	19.63	18.38	35.13	34.12	43.63	39.75	13.25	1.25	

\* Represents options.

## Notes:

- 1) Removable base mounting brackets are supplied with unit at no additional charge.
- 2) 1/2-12 UNC-2B Tabs, 4 points, 8 points on models AC - 30,35 & 40 (top & bottom) for optional mounting purposes.
- 3) Motor mounting bracket is rotated 90 degrees on AC - 5 & 10 units.
- 4) Louvers are manually adjustable. However, all units are available with a screen front as an option (specify when ordering).
- 5) All units are available with an optional preset 30 or 65-psi pressure bypass valve. (see note "i" in maintenance on page 143)
- 6) All units can be connected in one or Two Pass configuration. Refer to piping instructions for detailed operating and maintenance information.

Example of a model:

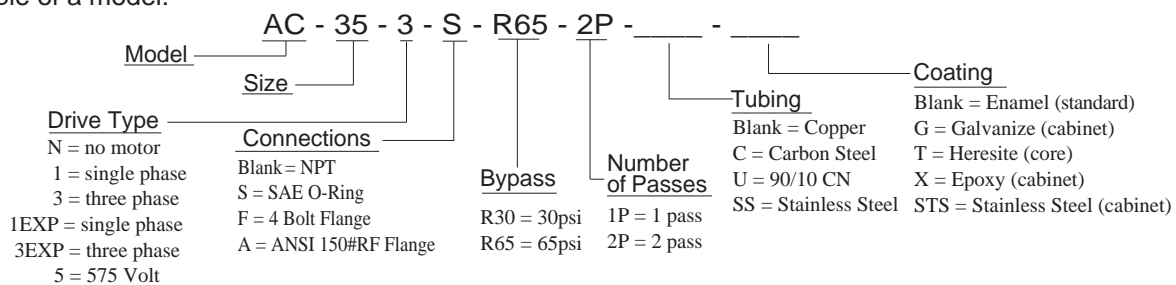

## AC ELECTRIC MOTOR @ 60 Hz. DATA

Model	Horse Power	Phase	Hz	Volts	RPM	NEMA Frame	Type	Full Load Amperes	Service Factor	Thermal Overload
AC-5, AC-10, AC-15, AC-20	1/4	1	60	115/230	1800	48	TEFC	2.6/1.3	1.15	No
AC-5, AC-10, AC-15, AC-20	1/4	3	60	208-230/460	1800	48	TEFC	1.4/0.7	1.0	No
AC-5, AC-10, AC-15, AC-20	1/3	3	60	575	1800	56	TEFC	0.6	1.15	No
AC-25 , AC-30	1/4	1	60	115/208-230	1200	48	TEFC	6.4/3.2	1.0	No
AC-25 , AC-30	1/4	3	60	208-230/460	1200	48	TEFC	1.4/0.7	1.0	No
AC-25 , AC-30	1/2	3	60	575	1200	56	TEFC	1.0	1.15	No
AC-35 , AC-40	1/2	1	60	115/208-230	1200	56	TEFC	8.0/4.0	1.0	No
AC-35 , AC-40	1/2	3	60	208-230/460	1200	56	TEFC	2.4/1.2	1.0	No
AC-35 , AC-40	1/2	3	60	575	1200	56	TEFC	1.0	1.15	No

## AC ELECTRIC MOTOR @ 50 Hz. DATA

Model	Horse Power	Phase	Hz	Volts	RPM	NEMA Frame	Type	Full Load Amperes	Service Factor	Thermal Overload
AC-5,10,15,20	1/3	1	50	110/220	1500	56	TEFC	6.4/3.2	1.15	No
AC-5,10,15,20	1/4	3	50	220/380	1500	48	TEFC	1.7/1.0	1.15	No
AC-25 , AC-30	1/3	1	50	110/220	1500	56	TEFC	6.4/3.2	1.15	No
AC-25 , AC-30	1/4	3	50	220/380	1500	48	TEFC	1.7/1.0	1.15	No
AC-35 , AC-40	1/2	1	50	110/220	1500	56	TEFC	6.4/3.6	1.0	No
AC-35 , AC-40	1/2	3	50	220/380	1500	56	TEFC	2.0/1.15	1.15	No

## CLASS I, DIV.1, GROUP D or CLASS II, DIV.2, GROUP F & G EXPLOSION PROOF MOTOR DATA

Model	Horse Power	Phase	Hz	Volts	RPM	NEMA Frame	Enclosure Type	Full Load Amperes	Service Factor	Thermal Overload
AC-5,10,15-EXP	1/4	1	60	115-208/230	1800	48	X-PROOF	5.0/2.5	1.0	Yes
AC-5,10,15-EXP	1/4	3	60	208-230/460	1800	48	X-PROOF	1.4/0.7	1.0	Yes
AC-20-EXP	1/2	1	60	115-208/230	1800	48	X-PROOF	7.4/3.7	1.0	Yes
AC-20-EXP	1/2	3	60	208-230/460	1800	48	X-PROOF	2.0/1.0	1.0	Yse
AC-25,30-EXP	1/2	1	60	115/230	1200	56	X-PROOF	8.0/4.0	1.0	Yes
AC-25,30-EXP	1/2	3	60	208-230/460	1200	56	X-PROOF	2.4/1.2	1.0	Yes
AC-35,40-EXP	1.0	1	60	115-208/230	1200	184	X-PROOF	14.0/7.0	1.0	No
AC-35,40-EXP	1.0	3	60	230/460	1200	56	X-PROOF	3.8/1.9	1.0	No

NOTE: All of the AC Series explosion proof motors are available in 50hz upon request as a special

### ELECTRIC MOTOR NOTES:

- 1) All motors are NEMA, high efficiency
- 2) Motor electrical ratings are an approximate guide and may vary between motor manufacturers. Consult ratings on motor data plate prior to installation and operation.
- 3) High temperature, severe duty, chemical, IEC, Canadian Standards Association, and Underwriters Laboratory recognized motors are available upon request.
- 4) American Industrial reserves the right to enact changes to motor brand, type and ratings regarding horsepower, RPM,FLA,and service factor for standard products without notice. All specific

requirements will be honored without change.

- 5) Fan rotation is clockwise when facing the motor shaft.
- 6) The above motors contain factory lubricated shielded ball bearings (no additional lubrication is required).

### 7) Abbreviation Index

TEFC.....Totally Enclosed, Fan Cooled  
X-PROOF.....Explosion Proof

# ACF Series *dimensions*

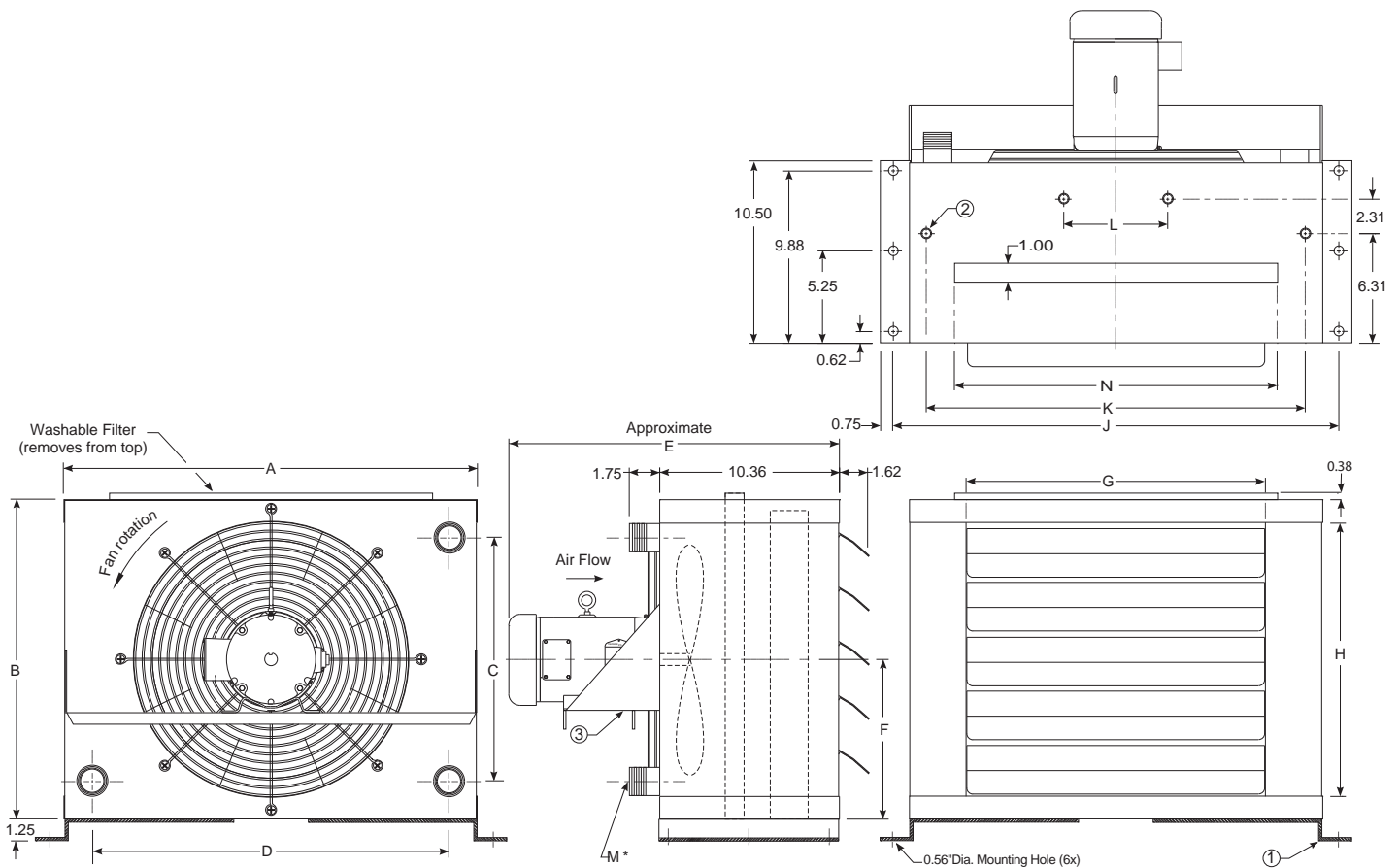

DIMENSIONS (inches)													
Model	A	B	C	D	E	F	G	H	J	K	L	M NPT	M SAE
ACF - 5 - *	14.81	11.81	7.69	11.69	17.56	5.90	8.31	9.19	16.81	12.94	—	1.00	16 SAE
ACF - 10 - *	19.00	13.13	8.88	15.88	17.13	6.56	12.50	10.50	21.00	17.13	—	1.00	1 5/16 - 12UN-2B Thread
ACF - 15 - *	20.38	15.75	11.50	17.25	17.44	7.88	13.88	13.12	22.38	18.50	—	1.00	
ACF - 20 - *	23.81	18.38	14.00	20.56	17.56	9.19	17.19	15.75	25.81	21.81	—	1.25	
ACF - 25 - *	26.68	23.63	19.25	23.56	17.56	11.81	20.19	21.00	28.68	24.81	—	1.25	20 SAE
ACF - 30 - *	31.63	27.56	23.19	28.50	17.63	13.78	25.13	24.94	33.63	29.75	11.00	1.25	1 5/8 - 12UN-2B Thread
ACF - 35 - *	33.81	30.19	25.81	30.69	20.75	15.09	27.31	27.56	35.81	31.94	11.00	1.25	
ACF - 40 - *	41.63	36.75	32.38	38.50	19.63	18.38	35.13	34.12	43.63	39.75	13.25	1.25	

\* Represents options.

## Notes:

- 1) Removable base mounting brackets are supplied with unit at no additional charge.
- 2) 1/2-12 UNC-2B Tabs, 4 points, 8 points on models ACF - 30, 35 & 40 (top & bottom) for optional mounting purposes.
- 3) Motor mounting bracket is rotated 90 degrees on ACF - 5 & 10 units.
- 4) Louvers are manually adjustable. However, all units are available with a screen front as an option (specify when ordering).

- 5) All units are available with an optional preset 30 or 65-psi pressure bypass valve. (see note "i" in maintenance on page 143)
- 6) All units can be connected in one or Two Pass configuration. Refer to piping instructions for detailed operating and maintenance information.
- 7) Filters are flame retardant, washable, and reusable woven synthetic with polyglass.

## Example of a model:

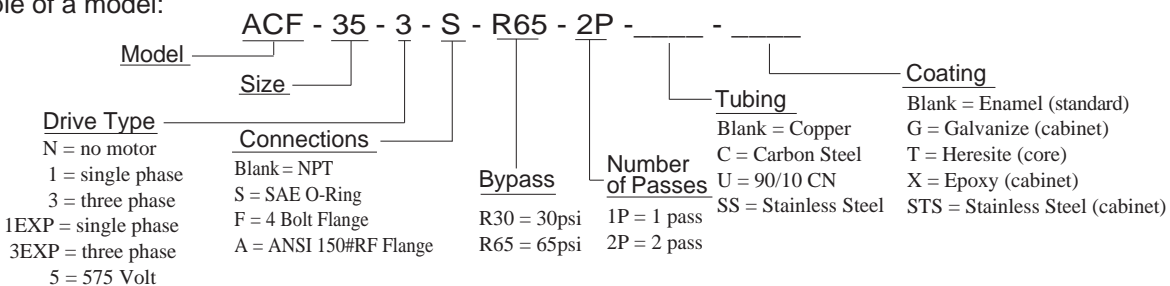



## ACF ELECTRIC MOTOR @ 60 Hz. DATA

Model	Horse Power	Phase	Hz	Volts	RPM	NEMA Frame	Type	Full Load Amperes	Service Factor	Thermal Overload
ACF-5,10,15	1/4	1	60	115/230	1800	48	TEFC	2.6/1.3	1.15	No
ACF-5,10,15	1/4	3	60	208-230/460	1800	48	TEFC	1.4/0.7	1.0	No
ACF-5,10,15	1/3	3	60	575	1800	56	TEFC	0.6	1.15	No
ACF-20	1/2	1	60	115/208-230	1800	48	TEFC	7.4/3.7	1.0	No
ACF-20	1/2	3	60	208/230-460	1800	48	TEFC	2.0/1.0	1.0	No
ACF-20	1/3	3	60	575	1800	56	TEFC	0.6	1.15	No
ACF-25 , ACF-30	1/2	1	60	115/208-230	1200	56	TEFC	8.0/4.0	1.0	No
ACF-25 , ACF-30	1/2	3	60	208-230/460	1200	56	TEFC	2.4/1.2	1.0	No
ACF-25 , ACF-30	1/2	3	60	575	1200	56	TEFC	1.0	1.15	No
ACF-35 , ACF-40	1.0	1	60	115/208-230	1200	184	TEFC	14.0/7.0	1.0	No
ACF-35 , ACF-40	1.0	3	60	208-230/460	1200	56	TEFC	3.6/1.8	1.15	No
ACF-35 , ACF-40	1/2	3	60	575	1200	56	TEFC	1.0	1.15	No

## ACF ELECTRIC MOTOR @ 50 Hz. DATA

Model	Horse Power	Phase	Hz	Volts	RPM	NEMA Frame	Type	Full Load Amperes	Service Factor	Thermal Overload
ACF-5,10,15	1/3	1	50	110/220	1500	56	TEFC	6.4/3.2	1.15	No
ACF-5,10,15	1/2	3	50	220/380	1500	56	TEFC	2.0/1.15	1.0	No
ACF-20	1/2	1	50	110/220	1500	56	TEFC	7.2/3.6	1.0	No
ACF-20	1/2	3	50	220/380	1500	56	TEFC	2.0/1.15	1.0	No
ACF-25,30	1/2	1	50	110/220	1500	48	TEFC	7.2/3.6	1.0	No
ACF-25,30	1/2	3	50	220/380	1500	56	TEFC	2.0/1.15	1.0	No
ACF-35,40	1.0	1	50	110/220	1500	56	TEFC	12.4/6.2	1.0	No
ACF-35,40	1.0	3	50	220/380	1500	143T	TEFC	3.5/2.0	1.0	No

## CLASS I,DIV.1, GROUP D or CLASS II,DIV.2, GROUP F & G EXPLOSION PROOF MOTOR DATA

Model	Horse Power	Phase	Hz	Volts	RPM	NEMA Frame	Enclosure Type	Full Load Amperes	Service Factor	Thermal Overload
ACF - 5,10,15 - 1 - EXP	1 / 4	1	60	115-208 / 230	1800	48	X-PROOF	5.0/2.5	1.0	Yes
ACF - 5,10,15 - 3 - EXP	1 / 4	3	60	208-230 / 460	1800	48	X-PROOF	1.4/0.7	1.0	Yes
ACF - 20 - 1 - EXP	1 / 2	1	60	115-208 / 230	1800	48	X-PROOF	7.4/3.7	1.0	Yes
ACF - 20 - 3 - EXP	1 / 2	3	60	208-230 / 460	1800	48	X-PROOF	2.0/1.0	1.0	Yes
ACF - 25,30 - 1 - EXP	1 / 2	1	60	115 / 230	1200	56	X-PROOF	8.0/4.0	1.0	Yes
ACF - 25,30 - 3 - EXP	1 / 2	3	60	208-230 / 460	1200	56	X-PROOF	2.4/1.2	1.0	Yes
ACF - 35,40 - 1 - EXP	1.0	1	60	115-208/230	1200	184	X-PROOF	14.0/7.0	1.0	No
ACF - 35,40 - 3 - EXP	1.0	3	60	230/460	1200	56	X-PROOF	3.8/1.9	1.0	No

NOTE: All of the ACF Series explosion proof motors are available in 50hz upon request as a special

### ELECTRIC MOTOR NOTES:

- 1) All motors are NEMA, high efficiency
- 2) Motor electrical ratings are an approximate guide and may vary between motor manufacturers. Consult ratings on motor data plate prior to installation and operation.
- 3) High temperature, severe duty, chemical, IEC, Canadian Standards Association, and Underwriters Laboratory recognized motors are available upon request.
- 4) American Industrial reserves the right to enact changes to motor brand, type and ratings regarding horsepower, RPM,FLA,and

service factor for standard products without notice. All specific requirements will be honored without change.

- 5) Fan rotation is clockwise when facing the motor shaft.
- 6) The above motors contain factory lubricated shielded ball bearings (no additional lubrication is required).

### 7) Abbreviation Index

TEFC.....Totally Enclosed, Fan Cooled  
X-PROOF.....Explosion Proof

# ACHM SERIES DIMENSIONS

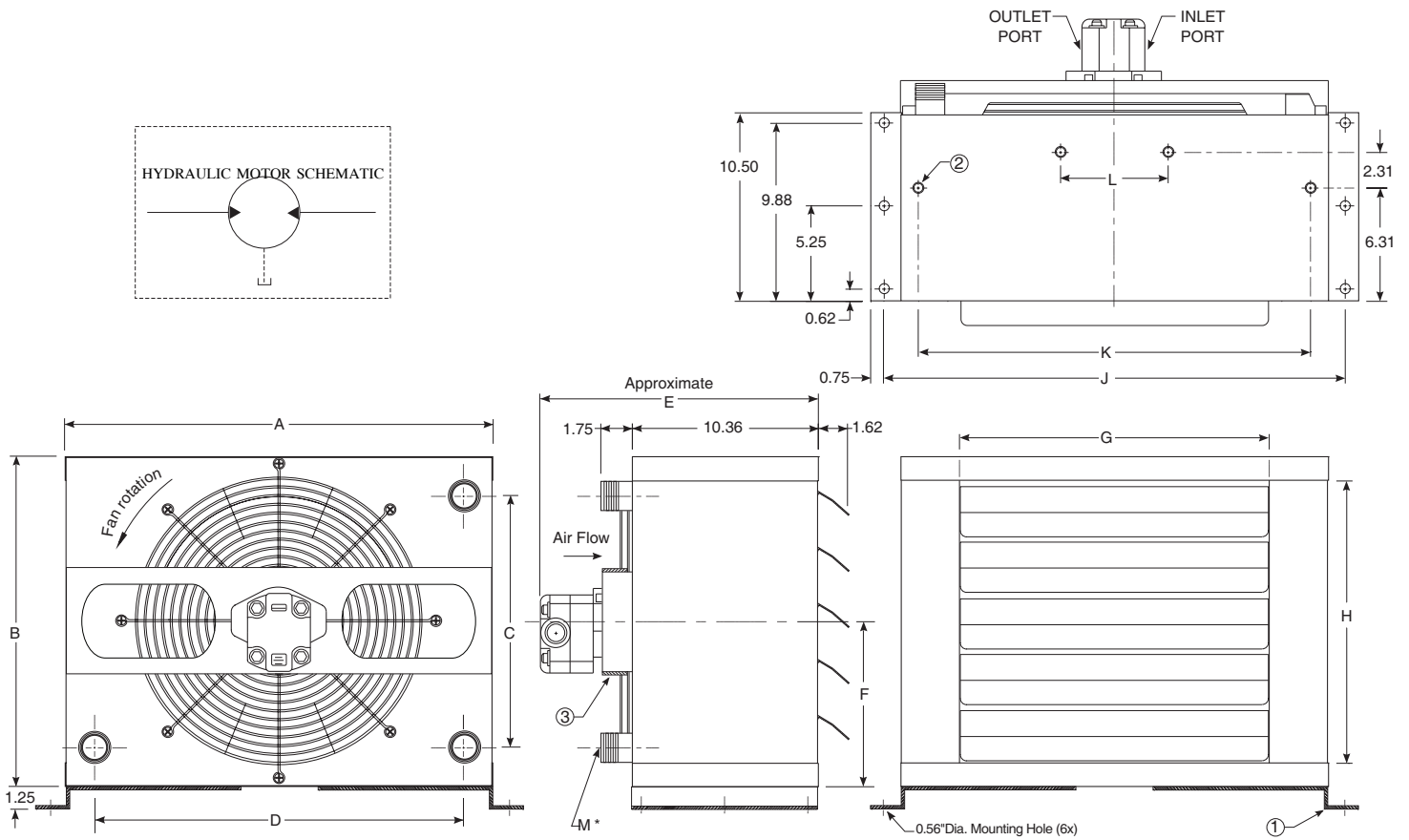

DIMENSIONS (inches)													
Model	A	B	C	D	E	F	G	H	J	K	L	M NPT	M SAE
ACHM - 5 - *	14.81	11.81	7.69	11.69	15.21	5.90	8.31	9.19	16.81	12.94	—	1.00	16 SAE
ACHM - 10 - *	19.00	13.13	8.88	15.88	15.21	6.56	12.50	10.50	21.00	17.13	—	1.00	1 5/16 - 12UN-2B
ACHM - 15 - *	20.38	15.75	11.50	17.25	15.21	7.88	13.88	13.12	22.38	18.50	—	1.00	Thread
ACHM - 20 - *	23.81	18.38	14.00	20.56	15.21	9.19	17.19	15.75	25.81	21.81	—	1.25	
ACHM - 25 - *	26.68	23.63	19.25	23.56	15.21	11.81	20.19	21.00	28.68	24.81	—	1.25	20 SAE
ACHM - 30 - *	31.63	27.56	23.19	28.50	15.21	13.78	25.13	24.94	33.63	29.75	11.00	1.25	1 5/8 - 12UN-2B
ACHM - 35 - *	33.81	30.19	25.81	30.69	15.21	15.09	27.31	27.56	35.81	31.94	11.00	1.25	Thread
ACHM - 40 - *	41.63	36.75	32.38	38.50	15.21	18.38	35.13	34.12	43.63	39.75	13.25	1.25	

\* Represents options.

## Notes:

- 1) Removable base mounting brackets are supplied with unit at no additional charge.
- 2) 1/2-12 UNC-2B Tabs, 4 points, 8 points on models ACHM - 30, 35 & 40 (top & bottom) for optional mounting purposes.
- 3) Motor mounting bracket is rotated 90 degrees on ACHM - 5 & 10 units.
- 4) Louvers are manually adjustable. However, all units are available with a screen front as an option (specify when ordering).
- 5) All units are available with a preset 30 or 65-psi pressure bypass valve. (see note "i" in maintenance page 143)
- 6) All units can be connected in one or Two Pass configuration. Refer to piping instructions for detailed operating and maintenance information.

Example of a model:

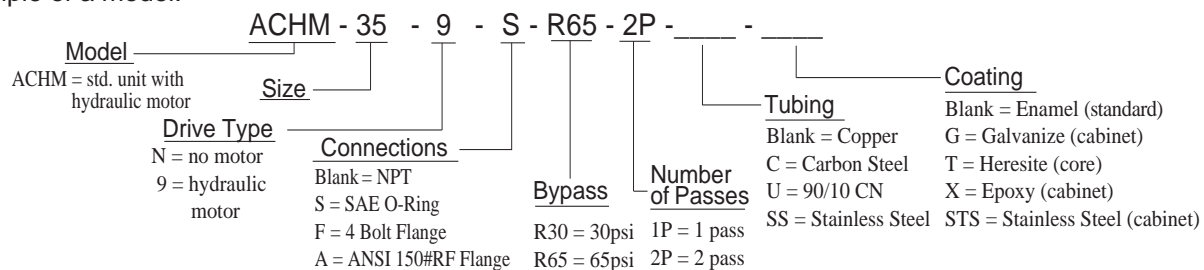

## HYDRAULIC MOTOR DATA

Model	Motor RPM	Displacement		Required Flow		Min. pressure start / run PSIG	Case Drain SAE O-Ring	SAE Size	Side Port SAE O-Ring	Max. Continuous Pressure PSIG
		in <sup>3</sup> /rev	ccm/rev	GPM	LPM					
ACHM - 5 - *	1725	0.43	7.0	3.75	14.2	500 / 300	#6 9/16 -18	A	#10 7/8 -14	3000
ACHM - 10 - *	1725	0.43	7.0	3.75	14.2	500 / 300	#6 9/16 -18	A	#10 7/8 -14	3000
ACHM - 15 - *	1725	0.43	7.0	3.75	14.2	500 / 300	#6 9/16 -18	A	#10 7/8 -14	3000
ACHM - 20 - *	1725	0.43	7.0	3.75	14.2	500 / 300	#6 9/16 -18	A	#10 7/8 -14	3000
ACHM - 25 - *	1140	0.43	7.0	2.50	9.5	500 / 300	#6 9/16 -18	A	#10 7/8 -14	3000
ACHM - 30 - *	1140	0.43	7.0	2.50	9.5	500 / 300	#6 9/16 -18	A	#10 7/8 -14	3000
ACHM - 35 - *	1140	0.43	7.0	2.50	9.5	600 / 400	#6 9/16 -18	A	#10 7/8 -14	3000
ACHM - 40 - *	1140	0.43	7.0	2.50	9.5	600 / 400	#6 9/16 -18	A	#10 7/8 -14	3000

### HYDRAULIC MOTOR NOTES:

- Standard ACHM units are supplied with a hydraulic gear motor for the fan drive. The gear motor requires an external case drain be used during operation. The external case drain should be connected directly to hydraulic reservoir or a return line with not greater than 10PSIG back pressure. (NOTE: *Failure to properly connect and use the external case drain during motor operation could result in motor failure and external leakage of hydraulic fluid.*)
- Hydraulic motor flow requirements are provided with an efficiency rating of approximately 85%. Pressure requirements are calculated theoretical minimum operating requirements.
- Shaft adapters are used to bridge the differences in length between the fan and hydraulic motor.
- Maximum degree of fluid contamination, class 18/15 according to ISO 4406. Therefore, it is recommended to use a filter with retention rating of B20>. For longer life, it is recommended to use class 17/14 achievable with filter B10>-100.
- Fan rotation is clockwise when facing the motor shaft.
- Optional displacement motors available upon request.
- American industrial reserves the right to enact changes to hydraulic motor, brand, type, ratings, port sizes, or any additional non-specified attribute for standard products without notice.

## COMMON DATA

Model	Air Flow		Sound Level dB(A) @ 7ft	Liquid Volume		Approx. Weight Electric		Approx. Weight Hydraulic		Serviceable Core
	CFM	m <sup>3</sup> /s		gal.	cm <sup>3</sup>	lb	kg	lb	kg	
Model - 5 - *	494	.233	68	.59	2233	65	30	55	25	No
Model - 10 - *	710	.335	70	.72	2725	85	39	75	34	No
Model - 15 - *	1015	.479	70	.85	3218	95	43	85	39	No
Model - 20 - *	1555	.733	71	1.15	4352	130	59	110	50	No
Model - 25 - *	2240	1.05	72	1.52	5753	165	75	150	68	No
Model - 30 - *	3100	1.46	75	1.88	7116	190	86	175	79	No
Model - 35 - *	4370	2.06	76	2.26	8554	235	107	220	100	No
Model - 40 - *	5450	2.51	78	2.95	11166	275	125	260	118	No

- NOTES: a) \* Represents the options for motor drive.  
 b) To estimate the sound level at distances other than 13 feet (4 meters) from the cooler, add 6 db for each halving of distance, or subtract 6 db for each doubling of the distance.

### PIPING HOOK UP *shown with relief valve*

