

American Industrial

Heat Transfer Inc.

Manufacturer of Quality Heat Exchangers

ACL SERIES

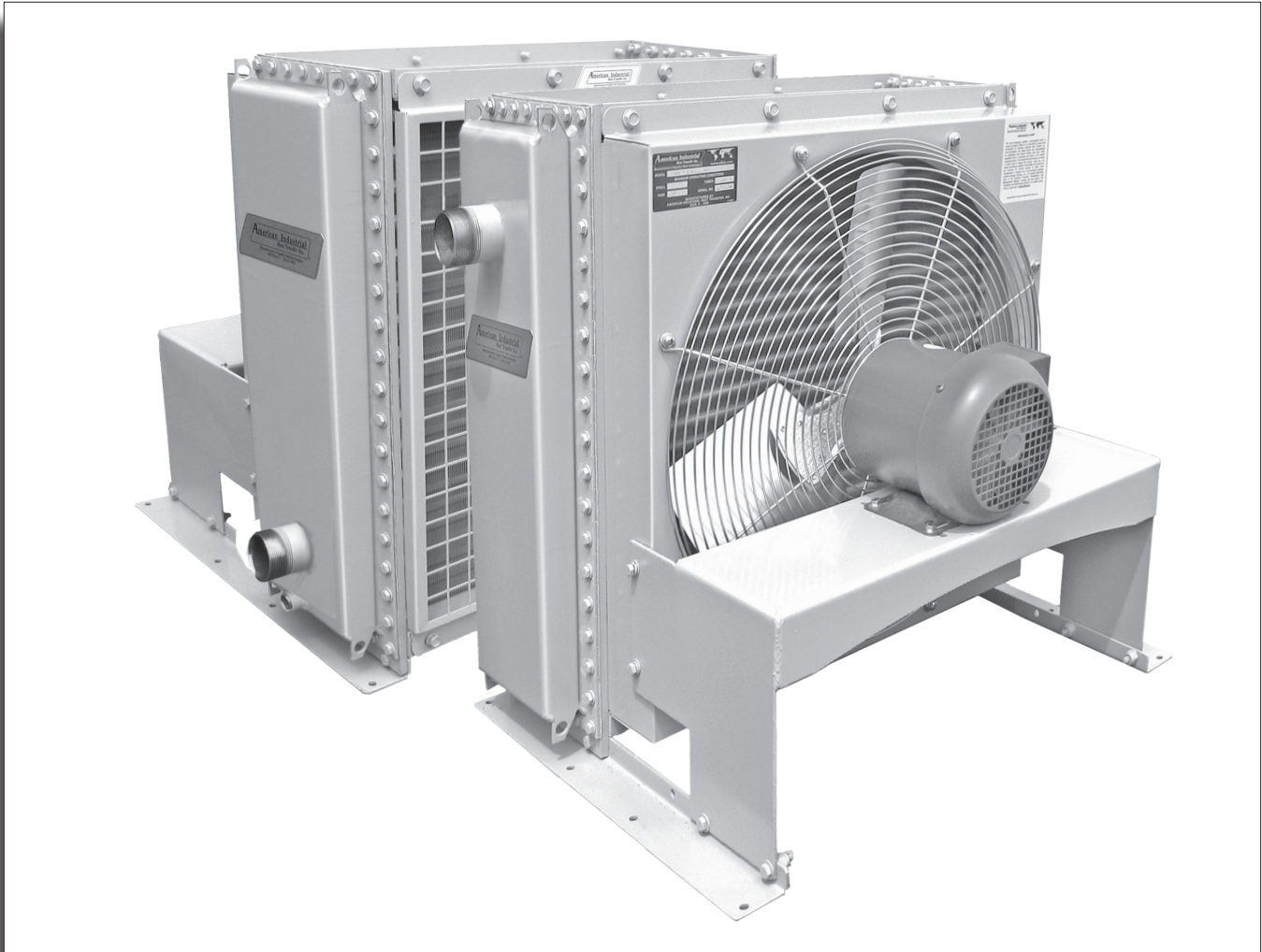

AIR COOLED

LIQUID COOLERS

- Severe duty construction with OSHA guard.
- Serviceable Core®.
- Thermal capacity to 1,400 hp (1,043 Kw).
- Operating temperature of 300°F at 300 PSI.
- Electric, hydraulic drive.
- Optional: built-in bypass valve.
- Can be customized to fit any applications.
- Computer generated data sheet available for any application
- Field changeable drive from electric to hydraulic.

ACL dimensions

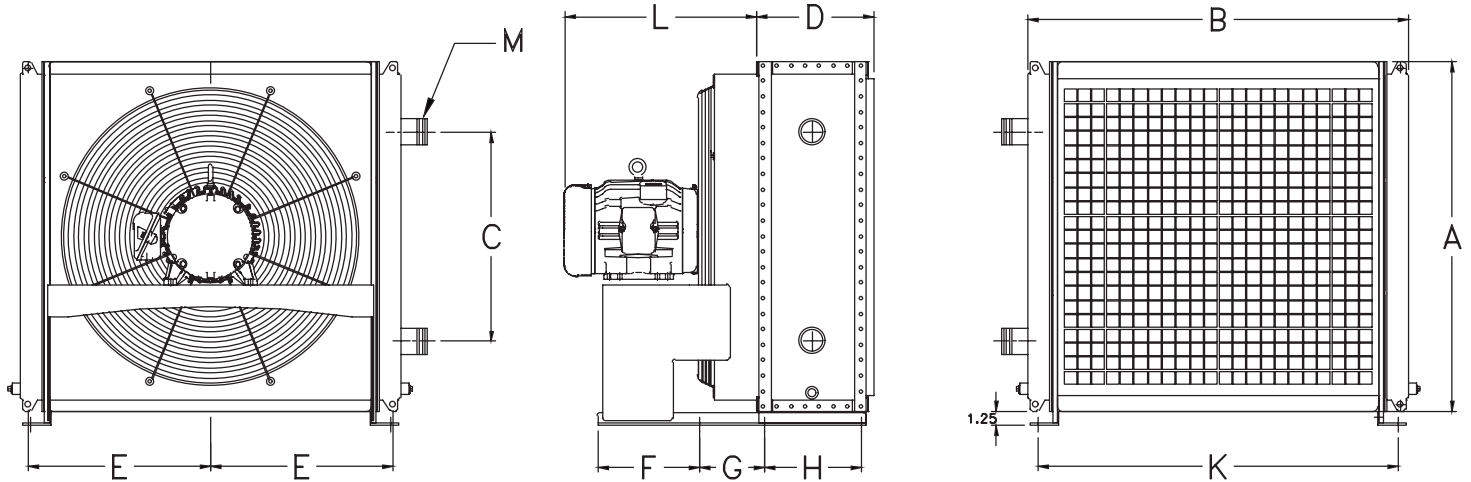

ACL - TWO Pass

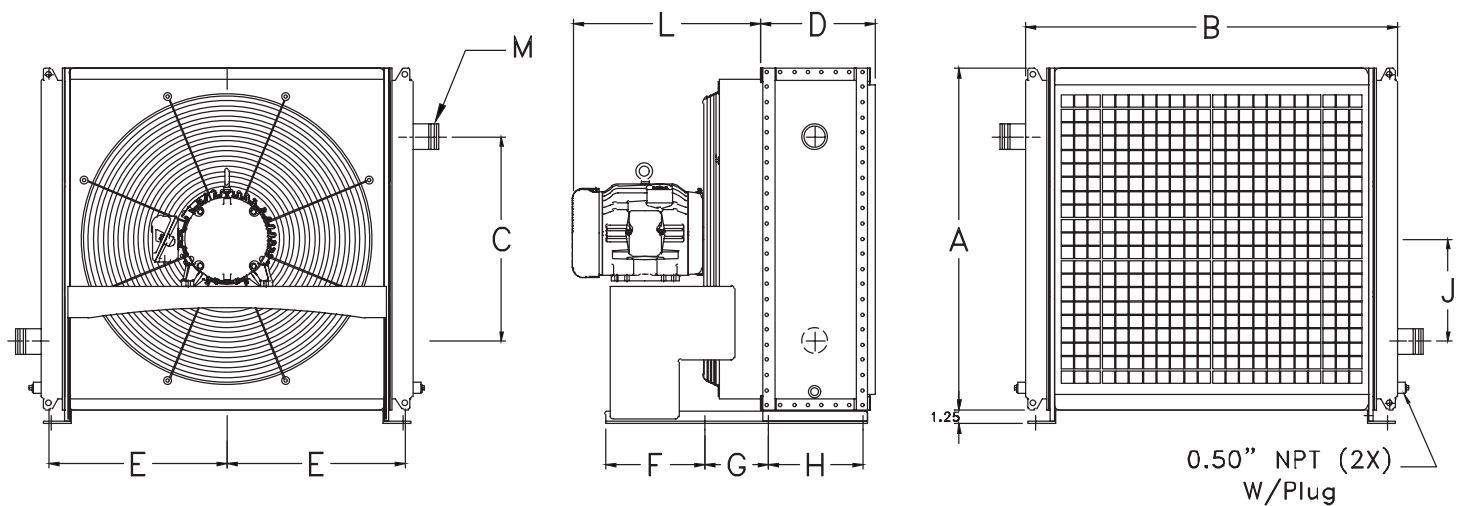

ACL - SINGLE / THREE PASS

DIMENSIONS (inches)

Model	A	B	C	D	E	F	G	H	J	K	L	M NPT
ACL - 1220	22.63	25.42	13.25	10.95	11.75	9.50	4.00	9.00	6.00	23.50	17.30	1.50
ACL - 1225	27.63	30.42	17.00	10.95	14.25	9.50	6.00	9.00	9.75	28.50	17.97	1.50
ACL - 1230	33.63	35.42	19.50	10.95	16.75	9.50	6.00	9.00	9.75	33.50	17.94	1.50
ACL - 1235	37.63	40.42	22.00	10.95	19.25	9.50	6.00	9.00	9.75	38.50	18.50	2.00
ACL - 1240	42.63	45.42	24.50	10.95	21.75	9.50	6.00	9.00	9.75	43.50	18.50	2.00
ACL - 1245	47.63	50.42	27.00	10.95	24.25	9.50	6.00	9.00	9.75	48.50	18.50	2.00
ACL - 1250	52.63	55.42	29.50	10.95	26.75	9.50	6.00	9.00	9.75	53.50	18.50	2.00
ACL - 1255	57.63	60.42	32.00	10.95	29.25	9.50	6.00	9.00	9.75	58.50	18.50	2.00